

# Rear Seats - Estates and Van

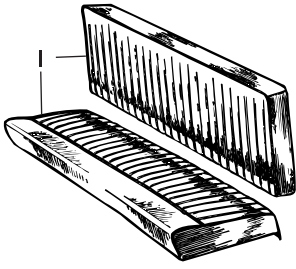

1960-61 Traveller and Countryman

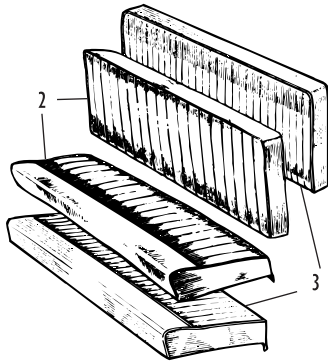

1961-67 Traveller and Countryman

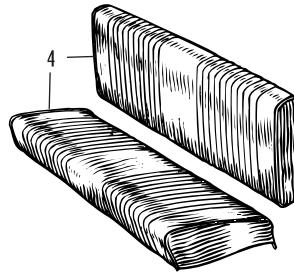

1967-69 Traveller and Countryman

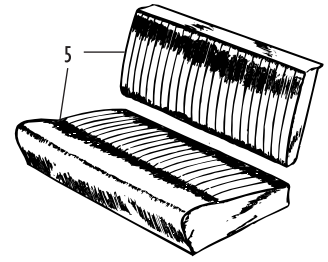

1960-69 Van

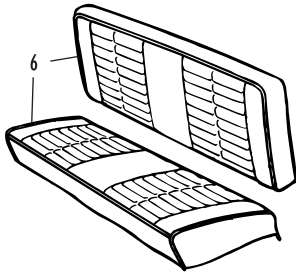

1969-75 Clubman Estate

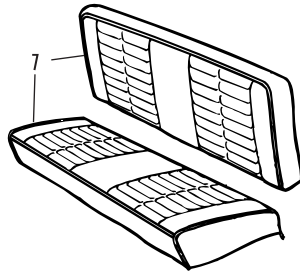

1976-80 Clubman Estate

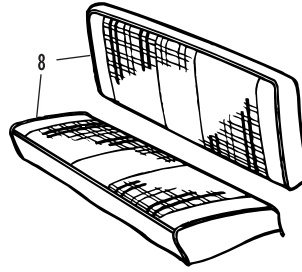

1980-82 HL (Clubman) Estate

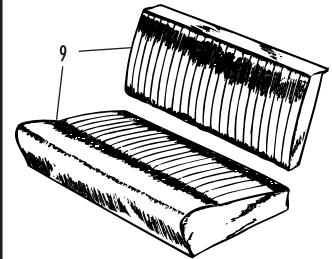

1969-84 Van

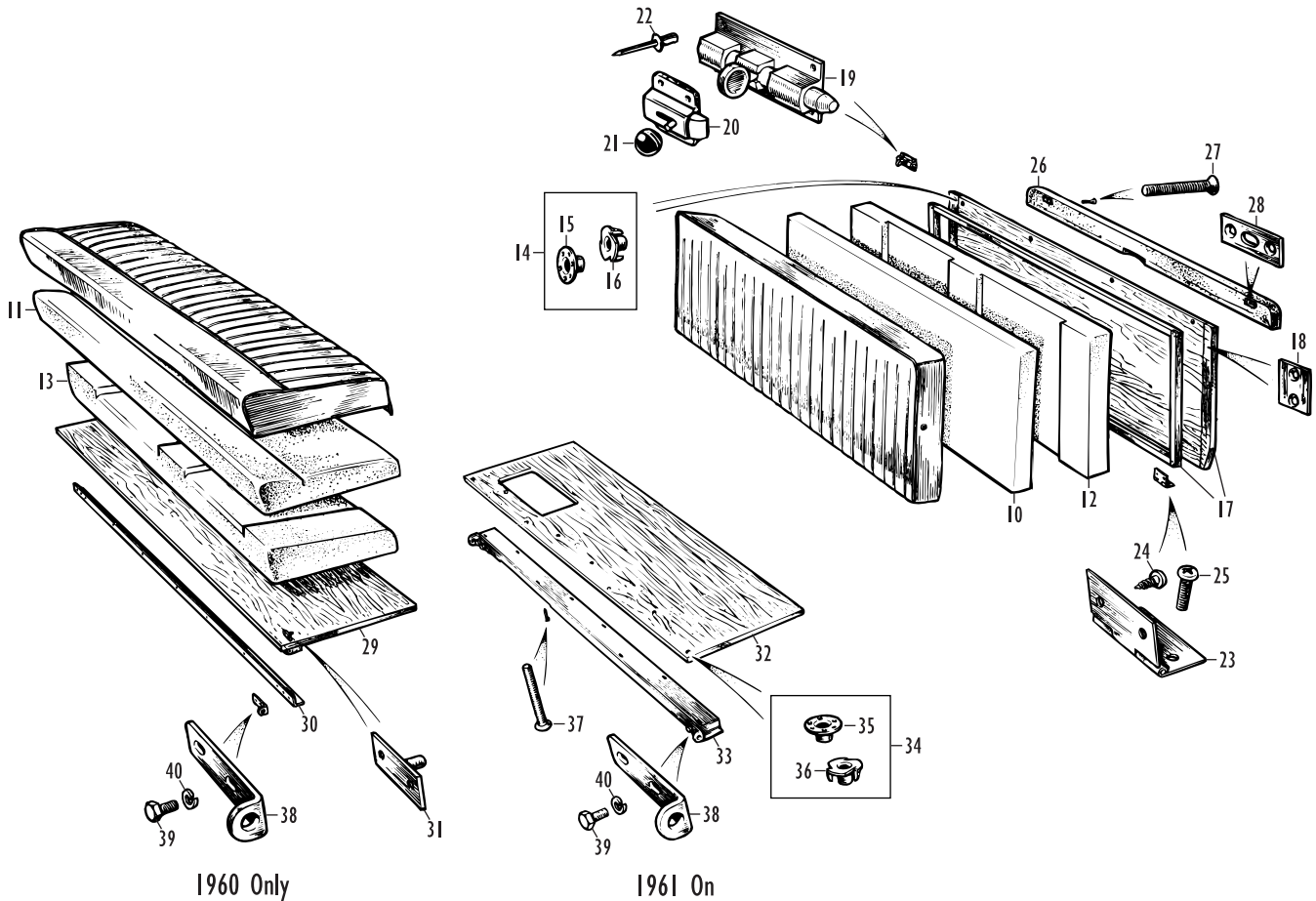

1960 Only

1961 On

© Copyright Somerford Mini Limited

# Rear Seats - Estates and Van

No.	Part No.	Description	Qty.	Remarks
-----	----------	-------------	------	---------

## Estate and Van Rear Seat Cover Kits

### Important Notes for Ordering Seat Cover Kits:

Please state model and year of your Mini, plus the colour(s) you require along with the part numbers when placing an order with Somerford Mini. This helps us ensure you receive the seat covers you need.

Note that because of the complex nature of seat colours and material types, only very popular items and colours (usually black) are held in stock - all others will be obtained to order, for which there will be a short lead time.

The carpet applied to the back of the rear seat squab in Mini estate models is available as part of the carpet sets detailed in the Somerford Mini catalogue Interior Carpets section.

Full details of the materials and patterns used for each style of rear seat are described in the front seat sections.

### Mk I Traveller and Countryman 1960-61

The following vinyl colour schemes are available:

Black/Grey Fleck, Porcelain Green/Grey Fleck, Tartan Red/Grey Fleck, Powder Blue/Grey Fleck, Spanish Red/Grey Fleck, Spanish Blue/Grey Fleck.

1	SC3111	REAR SEAT COVER KIT (state colour)	1	With stitched pleats.
---	--------	------------------------------------	---	-----------------------

### Mk I Traveller and Countryman 1961-67

The following vinyl colour schemes are available:

Cumulus Grey, Dove Grey, Porcelain Green, Powder Blue, Tartan Red.

2	SC3057	REAR SEAT COVER KIT (state colour)	1	With stitched pleats.
3	SC3056	REAR SEAT COVER KIT (state colour)	1	With heat welded pleats.

### Mk II Traveller and Countryman 1967-69

The following vinyl colour schemes are available:

Black, Tartan Red, Cumulus Grey.

4	SC3045	REAR SEAT COVER KIT (state colour)	1	
---	--------	------------------------------------	---	--

### Van with Wooden Load Floor (Optional) 1960-69

A black rear seat cover kit is available, to special order only.

5	SC3057A	REAR SEAT COVER KIT, Black	1	With stitched pleats.
---	---------	----------------------------	---	-----------------------

### Clubman Estate 1969-75

The following vinyl colour schemes are available:

Black, Navy.

6	SC3246	REAR SEAT COVER KIT (state colour)	1	
---	--------	------------------------------------	---	--

### Clubman Estate 1976-80

The original 'Deckchair' striped nylon and plain cropped nylon seat covers are no longer in production, but replacement vinyl covers to the 1969-75 style that will fit correctly are available as alternatives.

The following vinyl colour schemes (to replace the nylon originals) are available:

Black, Navy, Beige.

7	SC3246	REAR SEAT COVER KIT (state colour)	1	
---	--------	------------------------------------	---	--

### HL (Clubman) Estate 1980-82

The following plaid cloth colour schemes are available:

Golden Tan, Blue.

8	SC3319	REAR SEAT COVER KIT (state colour)	1	
---	--------	------------------------------------	---	--

### Van with Wooden Load Floor (Optional) 1969-84

A black rear seat cover kit is available, to special order only.

9	SC3056A	REAR SEAT COVER KIT, Black	1	With heat welded pleats.
---	---------	----------------------------	---	--------------------------

## Estate and Van Rear Seat Components

10	SF674	FOAM, rear seat squab	1	1960-67, Mk I Traveller and Countryman. 1960-84, Vans.
11	SF679	FOAM, rear seat cushion	1	1960-67, Mk I Traveller and Countryman. 1960-84, Vans.
12	SF675	FOAM, rear seat squab	1	1967-82, Mk II Traveller and Countryman, Clubman and HL Estates.
13	SF676	FOAM, rear seat cushion	1	1967-82, Mk II Traveller and Countryman, Clubman and HL Estates.
14	88G348	T NUT KIT, seat squab board	8	

No.	Part No.	Description	Qty.	Remarks
15	I4A7684	T NUT, male	8	Included in T nut kit.
16	I4B2876	T NUT, female	8	Included in T nut kit.
17	I4A7249	BOARD AND FRAME ASS'Y, seat squab	1	
18	I4A8657	PLATE, bearing, brass, seat squab catch	2	
19	I4A7267	BOLT, seat squab catch	2	1960-75.
20	CZH4084	LOCK, seat squab catch	2	1976 on.
21	CZH4076	KNOB, lock	2	1976 on.
22	DAP1045	RIVET, bolt to body	8	
23	I4B3500	HINGE, seat squab	2	
24	PTZ1204	SCREW, self tapping, hinge to body	4	
25	PMZ408	SCREW, hinge to seat squab board	4	
26	CZH4194	TOP RAIL ASSEMBLY, painted, Black	1	1976 on (cover with trim coloured vinyl for 1960-75 models).
27	CMP422	SCREW, top rail to seat squab board	4	
28	I4A7428	PLATE, location	2	

From the end of 1960 the battery was relocated from under the luggage floor to under the rear seat. This necessitated new designs of seat cushion board and support rail to provide the correct clearance for the top of the battery. At the same time, the screws attaching the board were strengthened from wood screws to set screws and T nuts, and the two pegs locating the seat squab when it was folded down were made an integral part of the support rail:

29	I4A7250	BOARD, seat cushion	1	1960 models with battery under luggage floor.
30	I4A7422	SUPPORT RAIL, seat cushion	1	1960 models with battery under luggage floor.
31	I4A7421	PEG, locating folded seat squab	2	1960 models with battery under luggage floor.
32	I4A9051	BOARD, seat cushion	1	1961 on models with battery under rear seat.
33	I4A8208	SUPPORT RAIL, seat cushion	1	1961 on models with battery under rear seat.
34	88G348	T NUT KIT, seat cushion board	8	1961 on models with battery under rear seat.
35	I4A7684	T NUT, male	8	Included in T nut kit.
36	I4B2876	T NUT, female	8	Included in T nut kit.
37	PMZ410	SCREW, board to support rail	8	1961 on models with battery under rear seat.
38	I4A7425	BRACKET, seat cushion pivot	2	
39	SH604041	SCREW, pivot bracket to support rail	4	
40	LWZ204	WASHER, locking	4	

## Somerford Mini Restoration Service

Somerford Mini Ltd. enjoys a reputation as one of the leading Mini restoration companies. We are small enough to guarantee a personal service, which we think is very important. Usually two people work on one car from start to finish, through every stage of the restoration. This ensures that the car is given the full attention of the individual restorer and no mix-ups can occur. You can also be assured of their full attention and enthusiasm. Another advantage which we regard as very important is that we have one person in full control of any work, from start to finish. We do not believe in pushing the car into a corner and working on it when we feel like it!

When we restore a Mini, we leave no stone unturned! The vehicle is completely dismantled; every single nut and bolt is stripped from the shell. It is perfectly normal to replace 60% of the car's panels. We use genuine Rover panels wherever possible and top quality reproduction panels where the originals are now obsolete. You will not find any cheap 'over panels' on our cars! Where panels butt together a weld-through sealant is used so that rust cannot find a new breeding ground. These panels are spotwelded into place for neatness and originality. Any remaining rust is shot blasted back to bare metal. The complete shell is then subjected to a thorough and time consuming painting and sealing process, using high quality corrosion-resistant primers and sealants. Once this is complete, the entire shell is resprayed inside, outside and underneath.

The vehicle is now ready for refitting. Wherever possible, the original components are reused if they are in serviceable condition. They are of course completely reconditioned - shot blasted and repainted or replated, as appropriate. New suspension joints, bushes, pipes, braking components etc. are fitted. The engine, gearbox, running gear and ancillaries are fully rebuilt; this means for example that engine blocks are rebored, new pistons fitted, crankshaft reground, and so on - not just new bearings fitted. The interior receives the same treatment with new carpets and trim being used where appropriate. During the whole process special attention is given to originality and detail. We are able to draw on our large stocks of spares, both new and secondhand, and are rarely unable to find that elusive part! The end result is a 'better than new' handbuilt Mini.

All work is carried out in-house by our dedicated team of enthusiasts, who all have a deep passion for the Mini and are able to draw on vast knowledge and experience. We place a strong emphasis on service and are proud of our work and reputation. We have customers and Somerford-restored cars all over the world.